

INSTALLATION INSTRUCTION

ITEM NO.: TYGRA03082A

DESCRIPTION: UNIVERSAL FRONT BUMPER

ATTENTION:

- Please read this installation menu before installing this part. Protect your car properly in case there is any scratch might have.
- You may need to periodically to re-tighten all hardware for safety use after installation.
- Installation pictures are only for your reference, there might be some differences between pictures and real parts but no affect for your fitting.

PART LIST:

NO.	NAME	QTY	REMARK	NO.	NAME	QTY	REMARK
1	MIDDLE BODY	1		7	Hexagon socket button head screws	12	M8*25
2	Upper tube	1		8	Flat Washer	24	Φ8*16*1.5
3	Wing protection tube(L)	1		9	Spring Washer	12	Φ8
4	Wing protection tube(R)	1		10	Hexagon Nut	12	M8
5	Motor board	1		11	Hex Wrenches	1	
6	φ22 rubber stopper	2		12			

INSTALLATION PICTURE

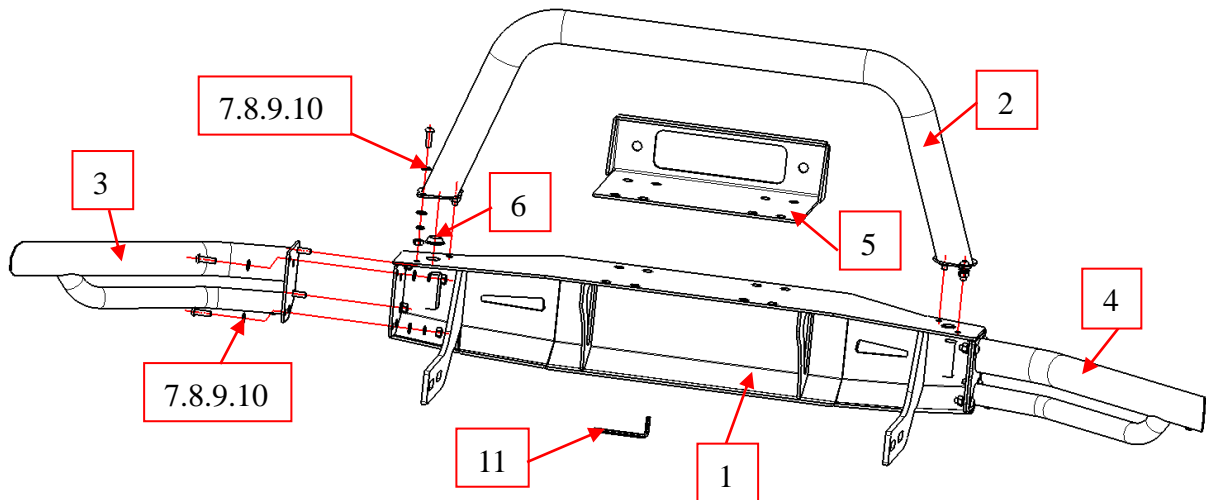

INSTALLATION PROCEDURE

- Step 1: Refer to Part List to check if all hard ware are included.
- Step 2: Install wing protection tubes (left/right) and upper tubes respectively according to the middle body hole position.
- Step 3: Install each accessory on the middle body, and then adjust the installation details according to the position of the accessories.
- Step 4: Check if all hard ware are installed and then fasten all to complete the installation.
- Step 5: Easy Install refer picture as follow.

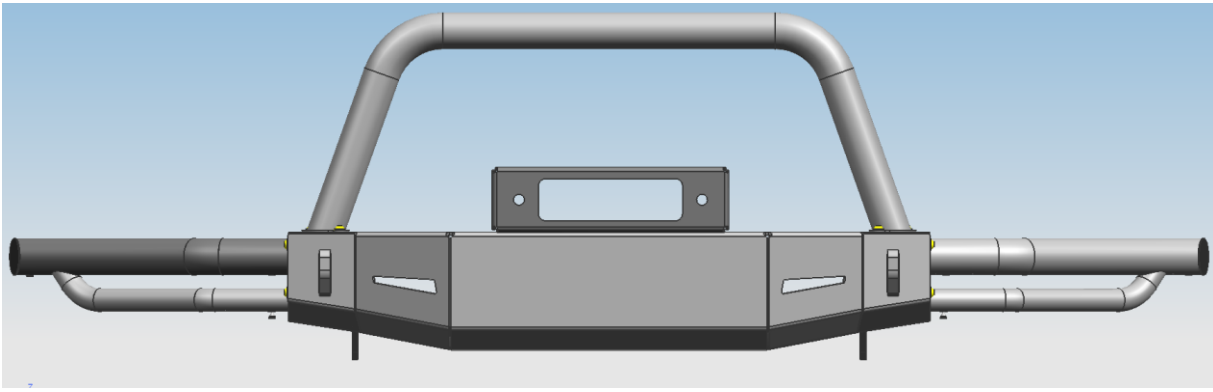

Disclaimer: Caused due to improper installation initiates or some related problem and losses, are beyond our company' s quality assurance.