







E-Tailgate lock for ISUZU D-MAX 2012-2020

Installation Instruction

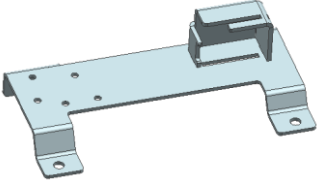
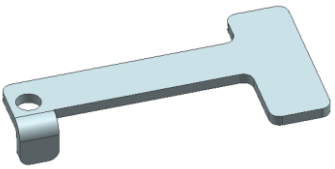
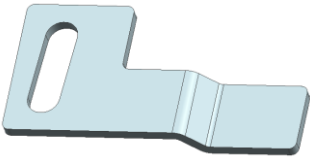
CAUTION:

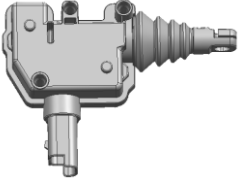

1. The figures here are for reference only and may have differences with the actual product you received, however they share the same assembly way.
2. Please read the instruction completely for easy installation, which will also help you to avoid scratches or other potential damages to your appealing car.

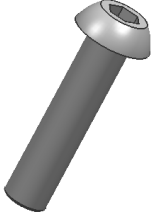
PART LIST:

NO.	QTY	NAME	NO.	QTY	NAME
①	1	 Bracket 1	②	1	 Bracket 2
③	1	 Bracket 3	④	1	 Wire harness (Universal)
⑤	1	 Actuator	⑥	2	 T-Shaped clamp (wire harness 0.2-0.5)
⑦	1	 Allen Wrench S=4	⑧	2	 M6 Flat Washer (6x18x1.6)
⑨	2	 Hexagon Socket Button Head Screws M6_15	⑩	1	 Hexagon Socket Button Head Screws M6_25

Item NO.: PW037929

Name: E-Tailgate lock for ISUZU D-MAX 2012-2020

⑪	3	 Hex flange nut M6	⑫	3	 Phillip tapping screw ST4.8_16
---	---	--	---	---	---

STEP ONE: Brackets Installation:

Remove the bedliner plate & steel cover plate on tailgate by loosening the screws.



Remove the original steel rod on vehicle.(as below picture shows)

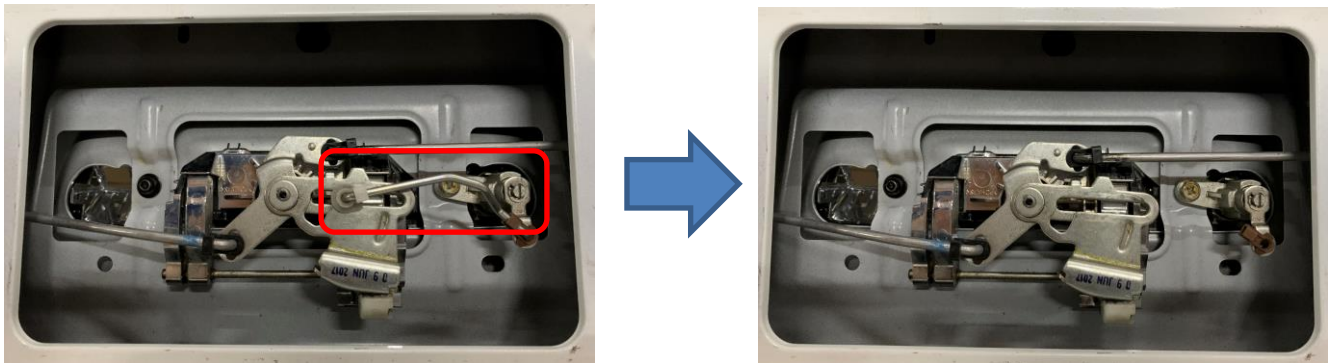

Installation Fig.

As below photo shows, install ① bracket 1, ② bracket 2 and ⑤ actuator with ⑧ ⑨ ⑩ ⑪ ⑫.

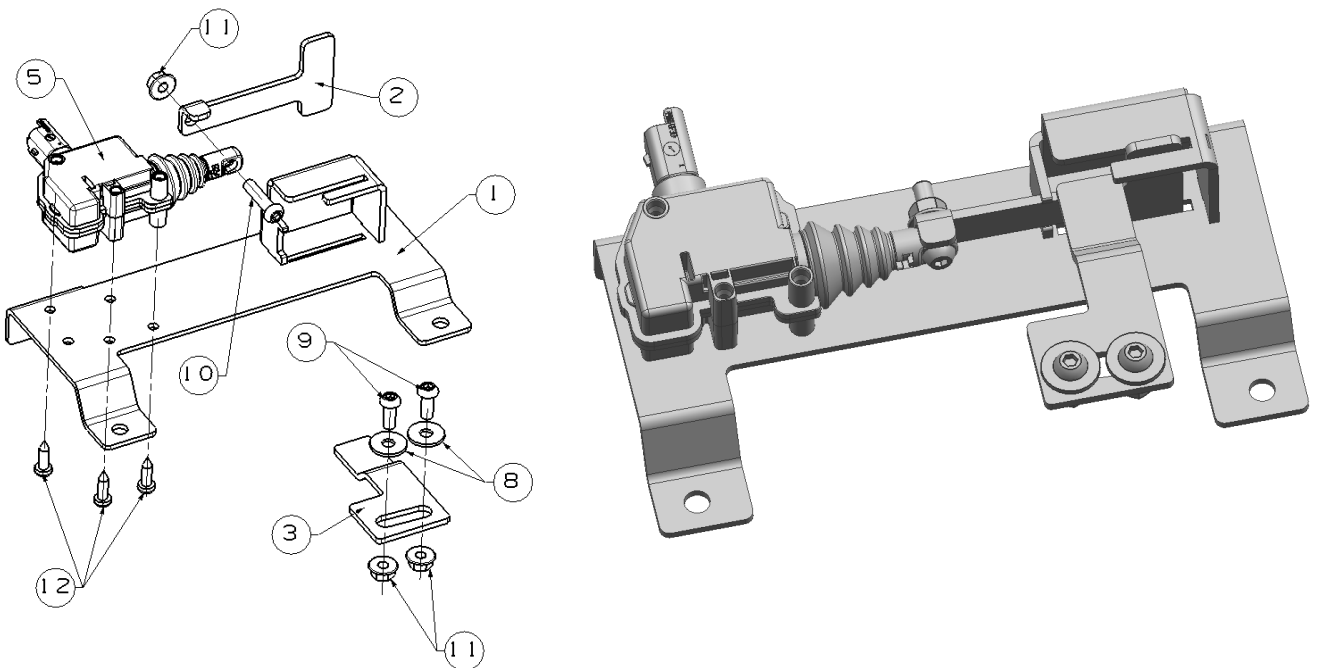

Item NO.: PW037929

Name: E-Tailgate lock for ISUZU D-MAX 2012-2020

Remove the two original screws, as below picture shows.

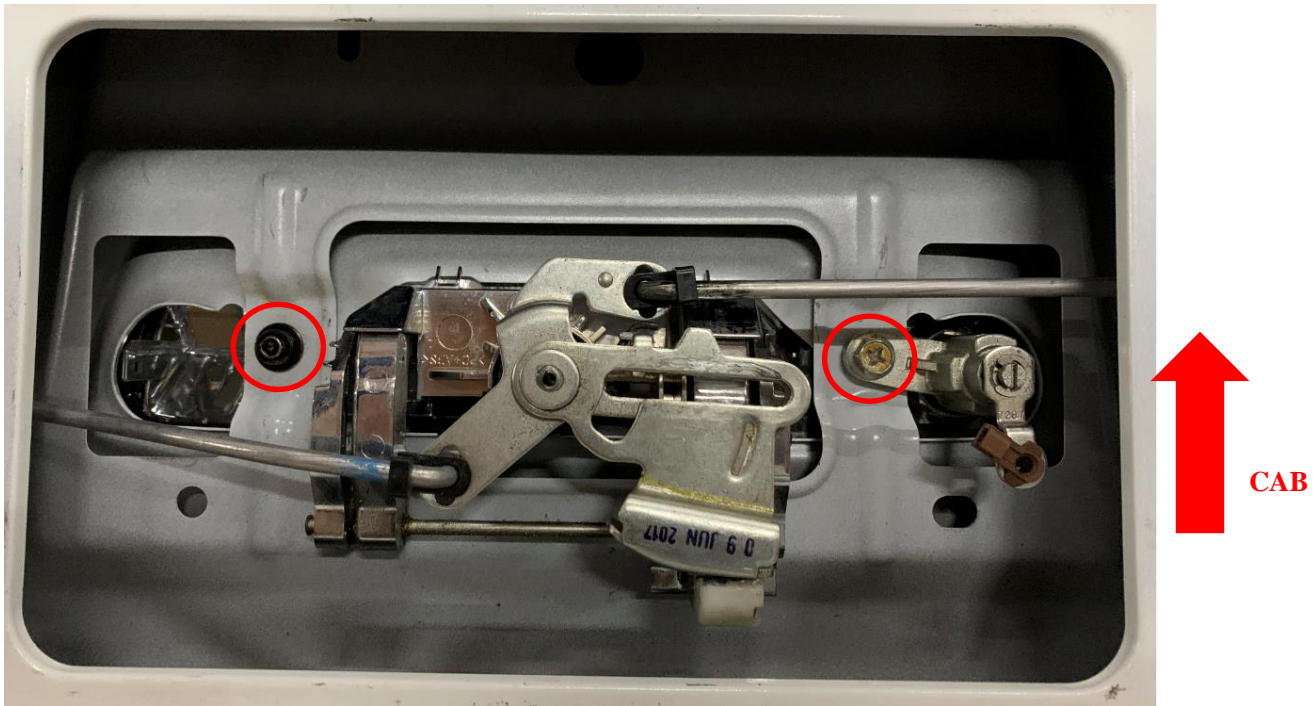

Install the bracket assembly into the tailgate, fasten it with the two original screws mentioned above.

Install ③ bracket 3 and fasten it with ⑧ ⑨ ⑪ :



Before reinstall the cover plate on tailgate, please test the locking function.

● Wiring harness connection:

1. Connect the wiring to the actuator the route the ④ actuator wiring harness out of the tailgate and underneath the vehicle.

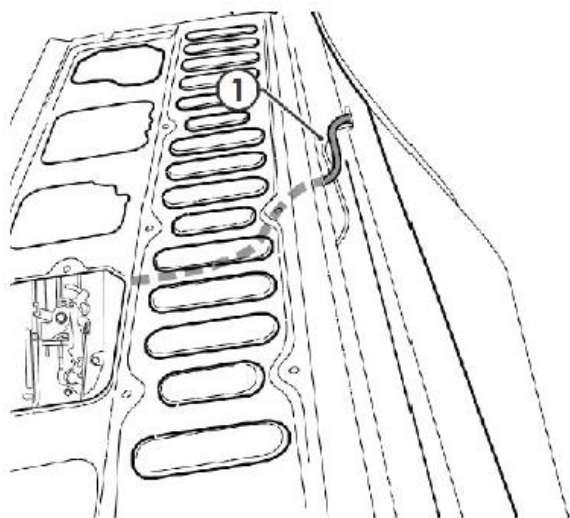

2. Route the wiring harness along the chassis rail to the driver seat.

