









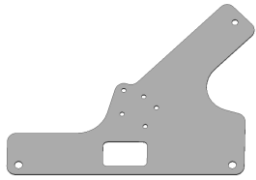

E-Tailgate lock for Ford Ranger 2012-2022

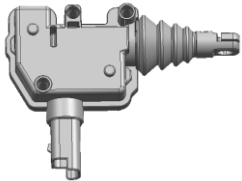
Installation Instruction

CAUTION:

1. The figures here are for reference only and may have differences with the actual product you received, however they share the same assembly way.
2. Please read the instruction completely for easy installation, which will also help you to avoid scratches or other potential damages to your appealing car.

PART LIST:

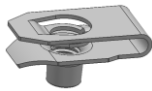
NO.	QTY	NAME	NO.	QTY	NAME
①	1	 Bracket 1	②	1	 Bracket 2
③	1	 Actuator	④	1	 Wire harness 1 (Universal)
⑤	1	 Wire harness 2 (connect fuel cap)	⑥	1	 Allen Wrench S=4
⑦	3	 M6 Spring Washer	⑧	3	 M6 Flat Washer (6x12x1.2)
⑨	4	 Hexagon Socket Button Head Screws M6_35	⑩	1	 Hex flange nut M6
⑪	3	 Phillip tapping screw ST4.8_16	⑫	3	 Clip Nut M6

STEP ONE: Brackets Installation:

Remove the bedliner plate & steel cover plate on tailgate by loosening the screws.



As below photo shows, remove these 3 plastic clips.



Installation Fig.

As below photo shows, install ① bracket 1, ② bracket 2 and ③ actuator with ⑨ ⑩ ⑪ ⑫.

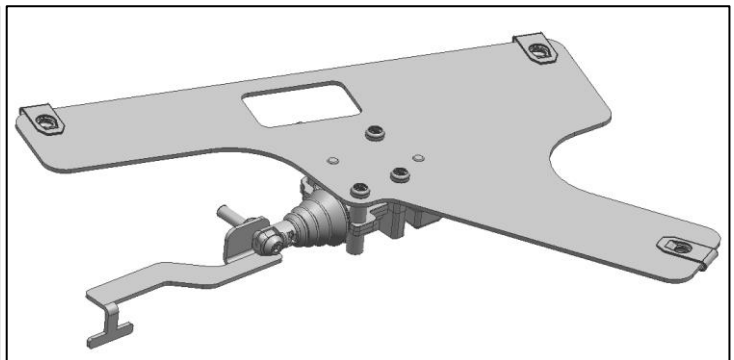
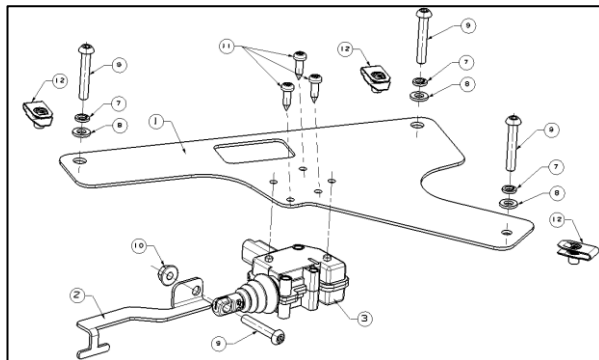

Then install the bracket inside of tailgate, fasten it with ⑦ ⑧ ⑨

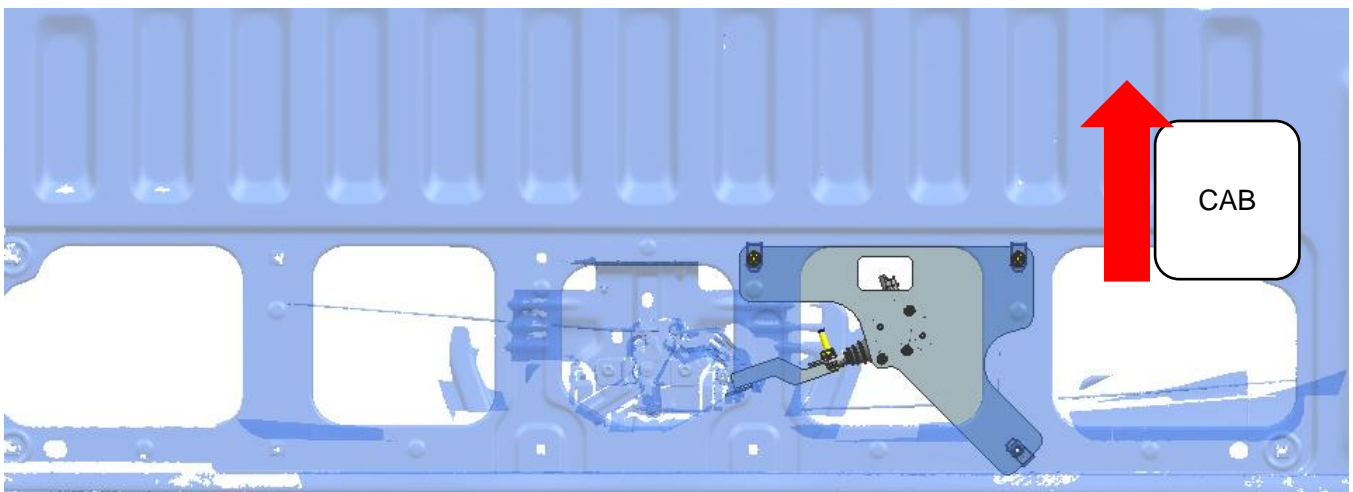

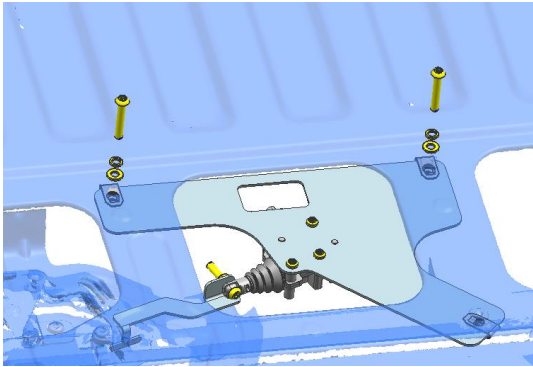

⚠ Notice:
The way we installed Bracket 2

Reinstall the steel cover plate and bedliner on tailgate.

⚠ Notice: As below picture shows, please fasten below hole with ⑦ ⑧ ⑨, instead of original bolt.

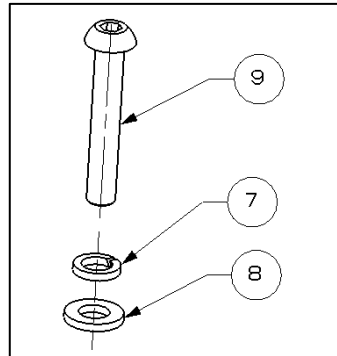

STEP TWO :

- Wire harness connection (Option 1):

Run the wire harness from tailgate to fender flare through chassis.

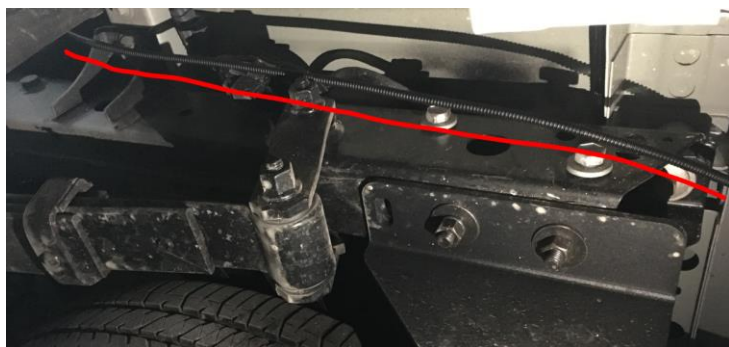
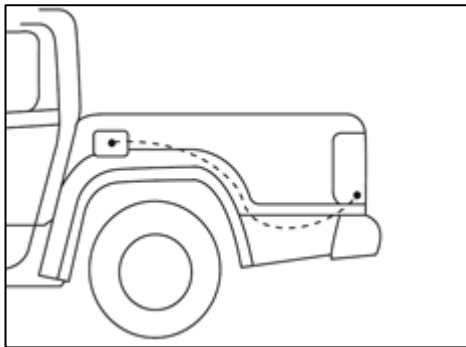

Disassemble fender flare by loosening the plastic screws.



Connect the wiring to the actuator the route the actuator wiring harness out of the tailgate and underneath the vehicle.

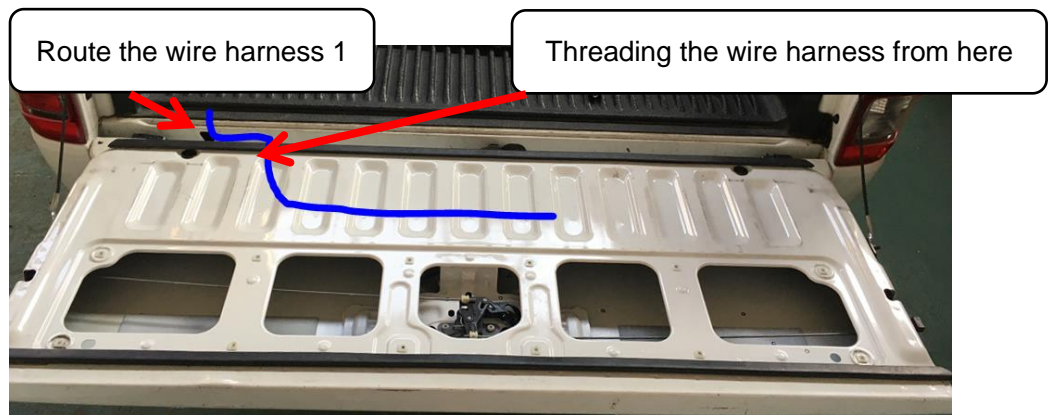

a. Run the wiring harness to fuel cap and reserved 20cm wire harness extra.



b. Take out the original actuator on fuel cap



c. As below picture shows,disconnect the fuel cap connector. Patch the shorter(two grey connectors) between the two fuel flap connectors.

fuel cap connector

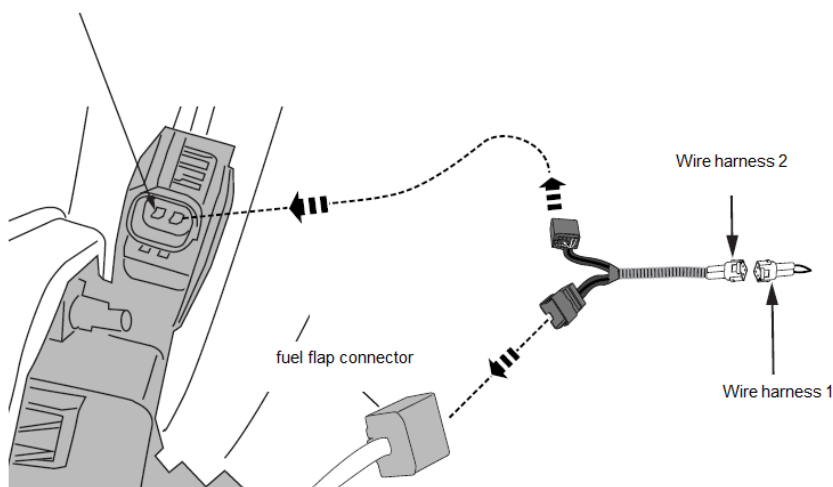

Test the tailgate lock function with the remote control. Then reinstall the fender flare and tailgate cover.
Finished

