

Care Instructions:



Do not slam bonnet.



Clean Bonnet Protector with mild detergent and water solution.



Do not use abrasive cleaners.



Do not use automatic car wash.



Est. Fitting Time: 20 mins

1.

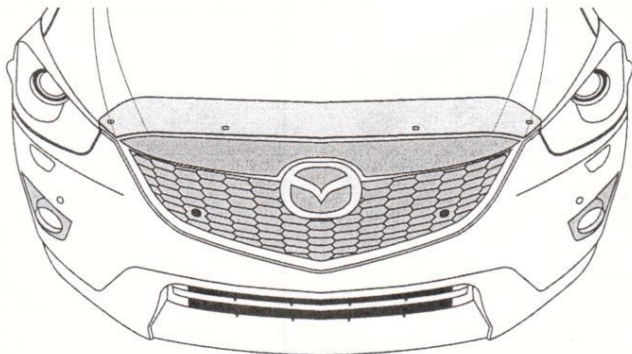

Open & clean the bonnet. Trial fit the Bonnet Protector centrally onto bonnet. Note the two centre slots in the Bonnet Protector that correspond to the plugs in the underside of the bonnet, using a non-permanent marker. Note the two outer slots on the Bonnet Protector and where they correspond on with the top of the bonnet.

2.

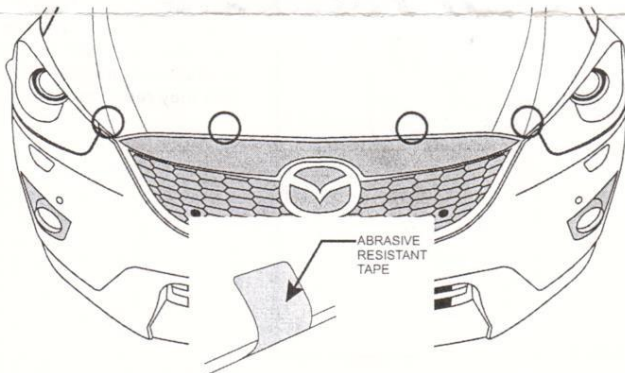

Clean the noted areas with alcohol wipe provided. Wipe off any residue with a dry clean cloth. Adhere the small abrasive resistant tape strips over the bonnet lip. Apply tape so approximately half of each strip is adhered to the topside and half is adhered to the underside of bonnet, as shown.

3.

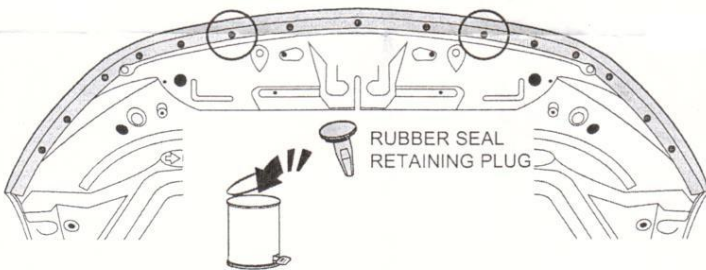

Remove and discard the 2 noted rubber seal-retaining plugs.

4.

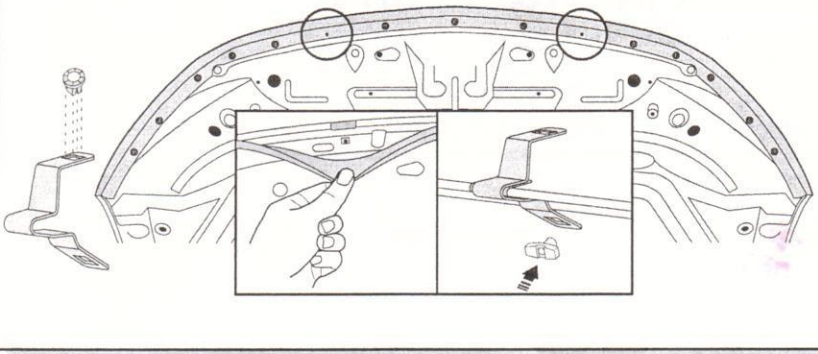

Press the nut insert into the centre metal clips. Pull down rubber seal and slide centre clips over the abrasive resistant tape. Insert screw plug through the clip into the bonnet.

IMPORTANT: Ensure the clips rest over the abrasive resistant tape and do not come in contact with bonnet paint work. Failure to do this may result in permanent paint damage.

5.

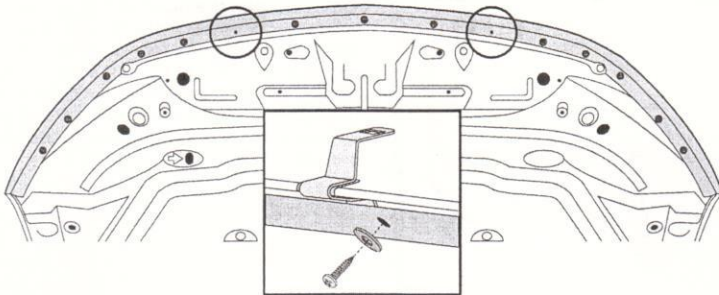

Put the rubber seal back into place. Insert self tapping screw through the washer and rubber seal into the screw plug, then tighten.

6.

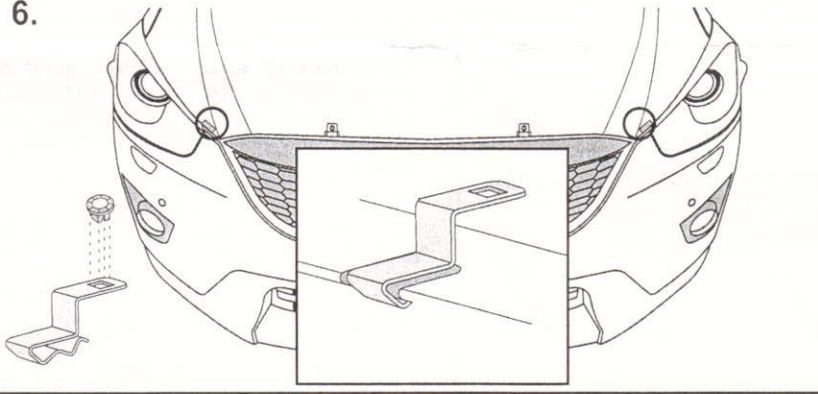

Press the nut insert into the wing clips. Slide the wing clips over the abrasive resistant tape.

IMPORTANT: Ensure the clips rest over the abrasive resistant tape and do not come in contact with bonnet paint work. Failure to do this may result in permanent paint damage.

7.

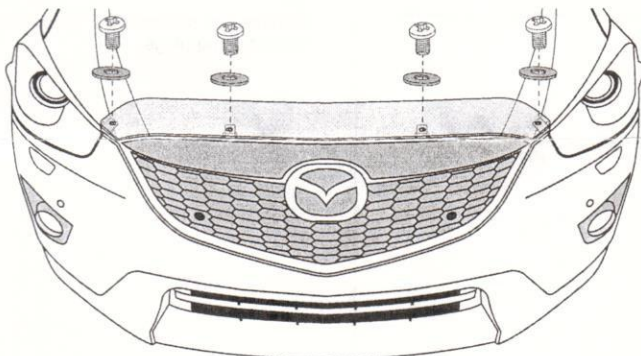

Re-Fit the Bonnet Protector centrally to bonnet, aligning the holes in the clips with the slots in the Bonnet Protector. Fix the Bonnet Protector to the clips using the screws and washers provided. **DO NOT OVERTIGHTEN SCREWS.**