

# INSTALLATION INSTRUCTION

ITEM NO.: W4-TUB-UNIHI-RK

DESCRIPTION: Universal Adjustable Ute Tub Rack Roof Tradie Steel Roll bar Ranger Hilux Triton Navara

Attention:

- Please read this installation menu before installing this part; Protect your car properly in case there is any scratch might have.
- You may need to periodically to re-tighten all hardware for safety use after installation.
- Installation pictures are only for your reference, there might be some differences between pictures and real parts but no effect for your fitting.

## PART LIST

No.	Name	QTY	Remark	No.	Name	QTY	Remark
1	Flat Washer	88	Φ8X20X1.0	12	Hexagon Nut	8	M8
2	Spring Washer	44	Φ8	13	Hexagon Socket Button Head Screws	8	M8
3	Hexagon Nut	44	M8	14	Aluminum Clip	8	
4	Hexagon Socket Button Head Screws	44	M8X25	15			
5	Base	4		16			
6	Side Rod	4		17			
7	Side Connecting Rod	2		18			
8	Vertical Connectors	4		19			
9	Top Crossbar	2		20			
10	Large Washer	16	Φ8*25*2.0	21			
11	Spring Washer	8	Φ8				

## INSTALLATION PICTUR

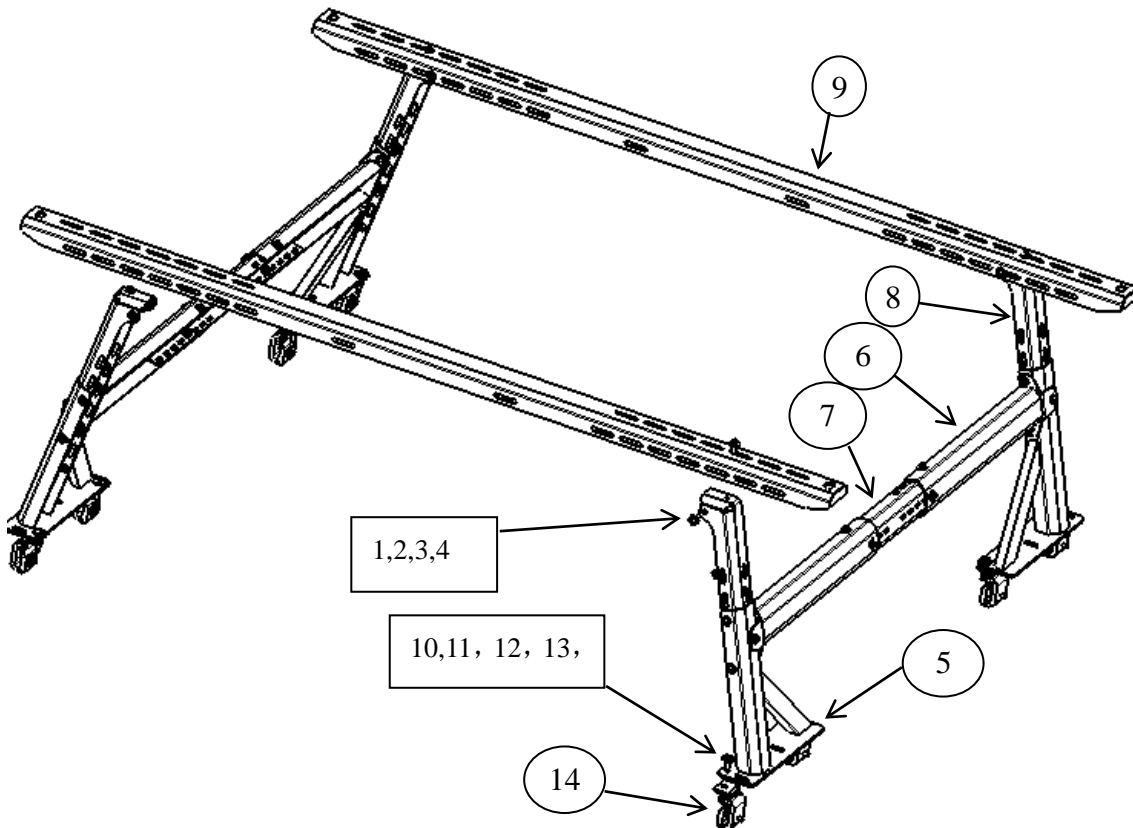

## INSTALLATION PROCEDURES

Step 1: Refer to the Part list to check if all the hardware are included.

Step 2: Assemble the Base/Side Rod/Side Connecting Rod and Top Crossbar with Flat Washer/Spring Washer/Hexagon Nut/Hexagon Socket Button Head Screws. The porous and elongated holes are used to adjust the installation height, length, and width according to the needs of the vehicle body

Step 3: Place the assembled main body on the vehicle, then use aluminum clips to grip the car, and fix with Large Washer/Spring Washer/Hexagon Nut/Hexagon Socket Button Head Screws on the aluminum clip hole. If the car is equipped with manual roller cover or other covers and it is not suitable to use aluminum clips, you can choose to align the installation holes on the base and drill holes on the car upper, then fix with Large Washer/Spring Washer/Hexagon Nut/Hexagon Socket Button Head Screws on the car upper.

Step 4: Check if all hardware are installed and tighten up. Complete the installation.

**Disclaimer:** Caused due to improper installation initiates or some related problem and losses, are beyond our company's quality assurance.