

User's Manual

Product Name: Electric Pedal Bracket For 2010+ Toyota Prado

1. Precautions

- 1.1 Please read the User's Manual carefully before installation. Pay attention to the outside appearance during operation in case of any scratch;
- 1.2 Please check regularly if all the connecting components are fixed tightly to ensure safety in use.
- 1.3 About the cable connection, Please follow the installation instructions strictly.
- 1.4 The ECU can't be flushed and soaked, Please note the location of the installation.
- 1.5 The ECU and cable must avoid engine casing, exhaust pipe and other high-temperature components.
- 1.6 It must avoid short circuit of 2 signal cables or with the vehicle body.
- 1.7 Tighten the connector of the motor for better waterproofing.

2. Preparation work

- 2.1 Check whether the product is in good condition and whether the accessories are complete.
- 2.2 Get the installation tools ready.

			
internal hexagonal wrench	knife	scissor	warped board
			
Double hexagonal socket wrench	slot type/cross screwdriver	socket spanner	open spanner

3. Accessories

No.	Name	Qty	Size	No.	Name	Qty	Size
1	Pedal	2		8	Plastic piece	8	
2	Front Bracket	2		9	U-shape bolt	8	50*14*10 M10*30
3	Rear Bracket	2		10	U-shape bolt	2	50*14*10 M10*35
4	ECU	1		11	U-shape bolt	2	70*18*25 M10*35
5	hexagon socket head cap screw	8	M6*20	12	hexagon nuts with flange	12	M10 nut
6	electrical adhesive tape	1		13	U shape washer	10	
7	Nylon cable ties	25		14			

4. ECU & Cable



Main cable



ECU



**positive pole
negative pole**



motor connter



OBD connter

5. Cable connection

5. 1 Connect the OBD-A with the OBD connector of the original vehicle ,

The picture below is for **2010-2017 Toyota Prado**:



The picture below is for **2018 Toyota Prado**:

5. 2 Cut the plug below and connect the cable (red and black)to the car using red cable clamp.



2018 Toyota Prado signal connection method one:



Disassemble the interior panel of the cab show above



Find the red connector show above

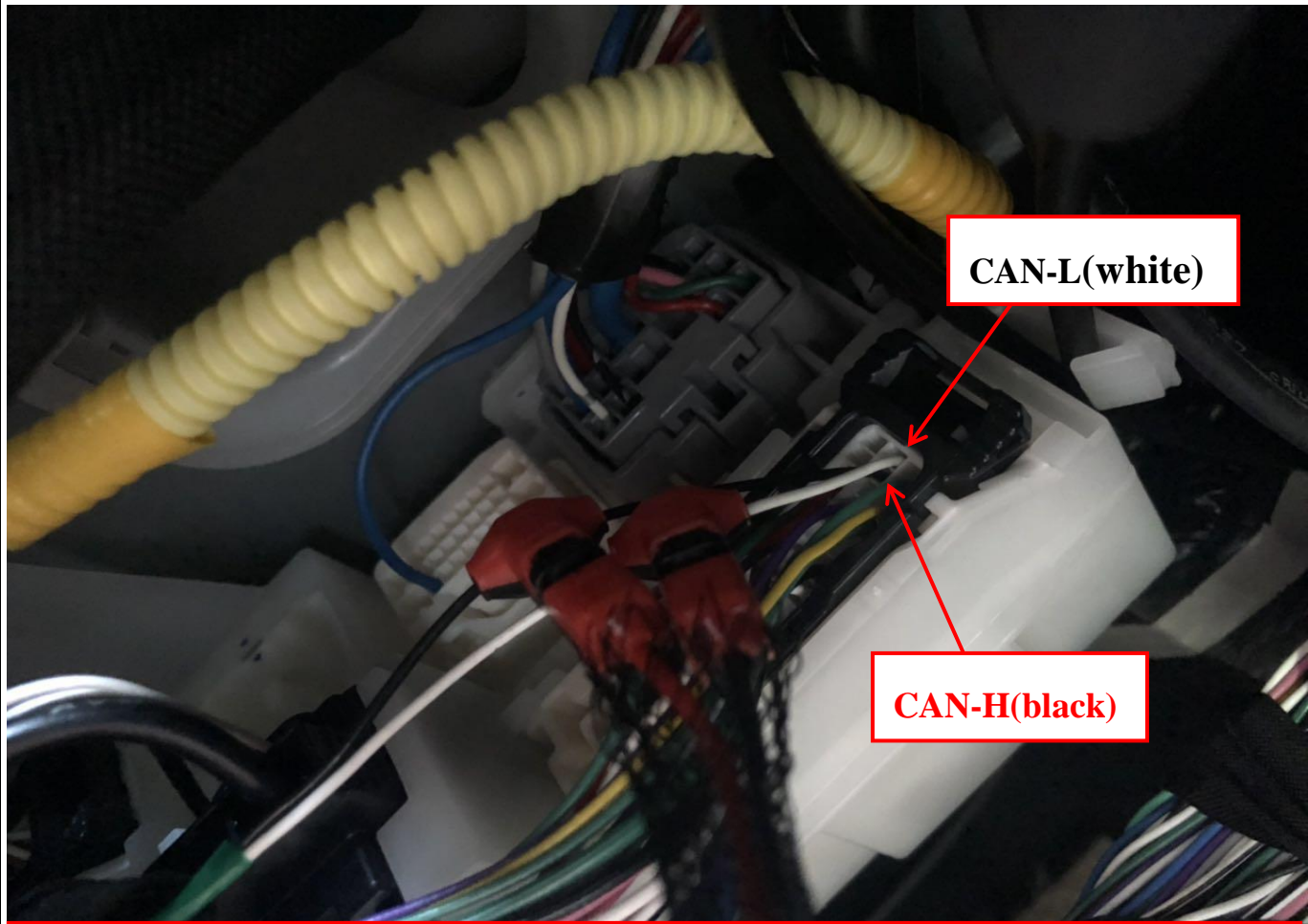

CAN-H to the red cable CAN-L to the black cable

2018 Toyota Prado signal connection method two :

Note:you can check this method for you reference if you do not find the connector in method one.

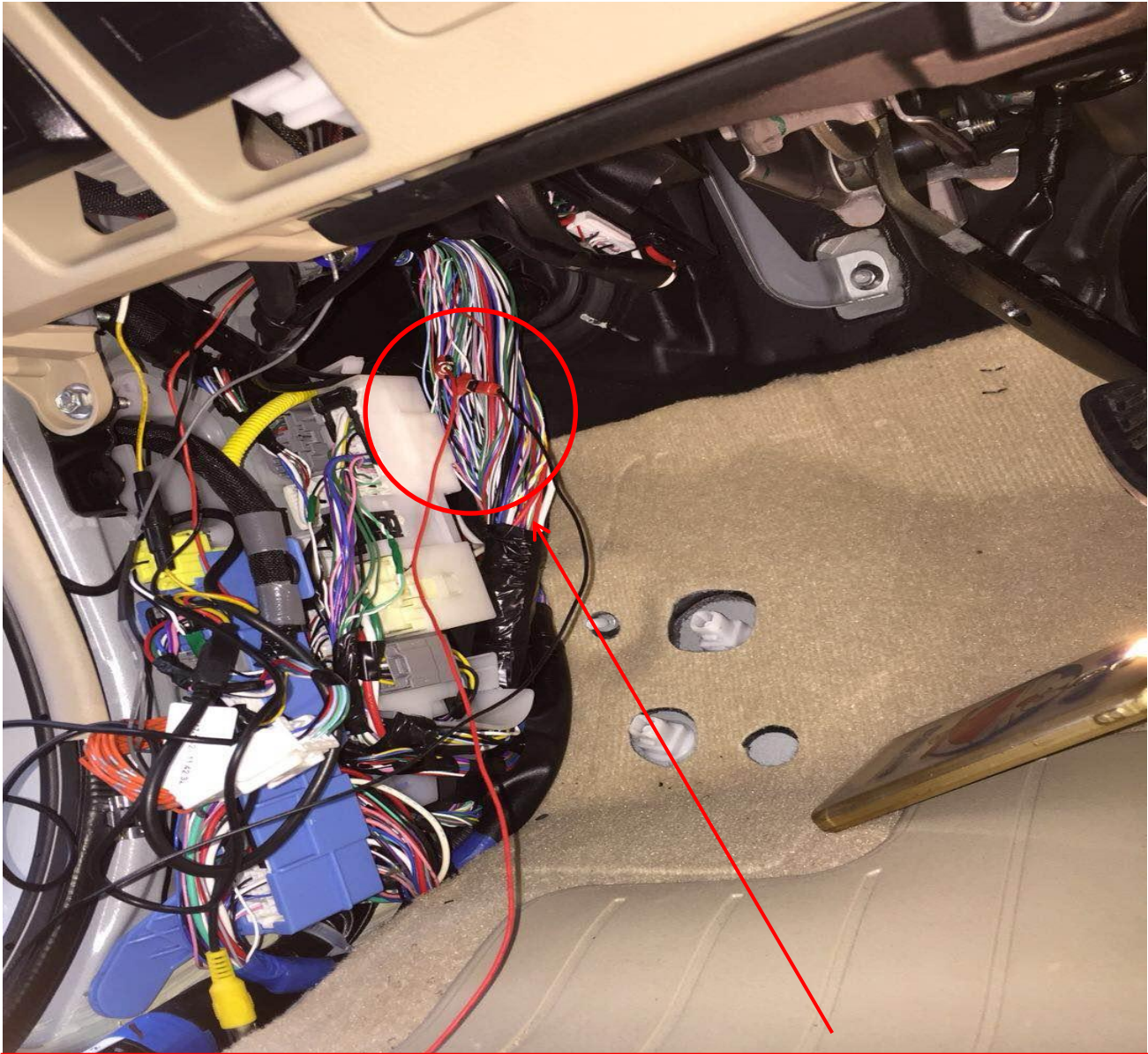

Disassemble the interior panel of the cab show above

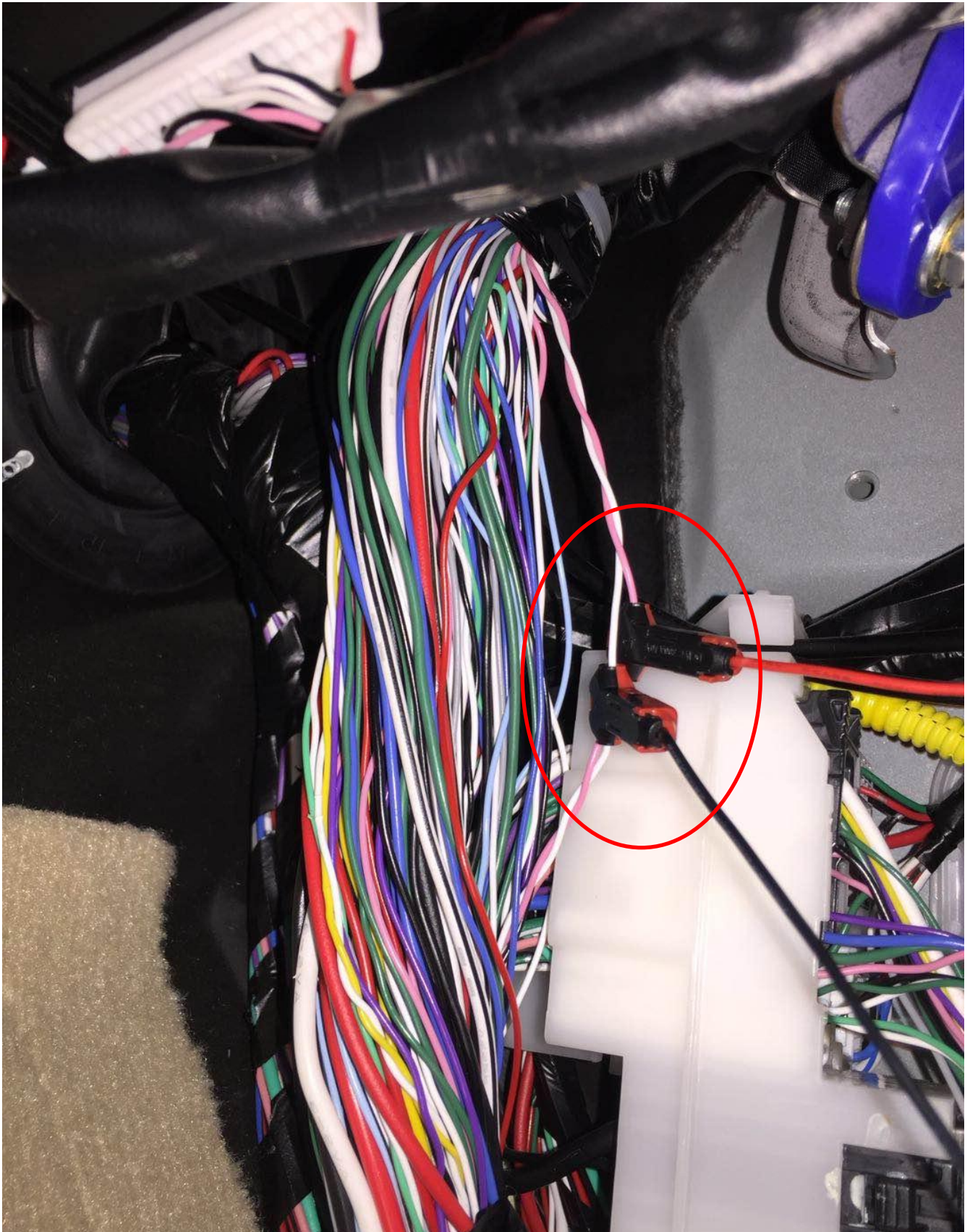

Find the twisted cable (pink & white)

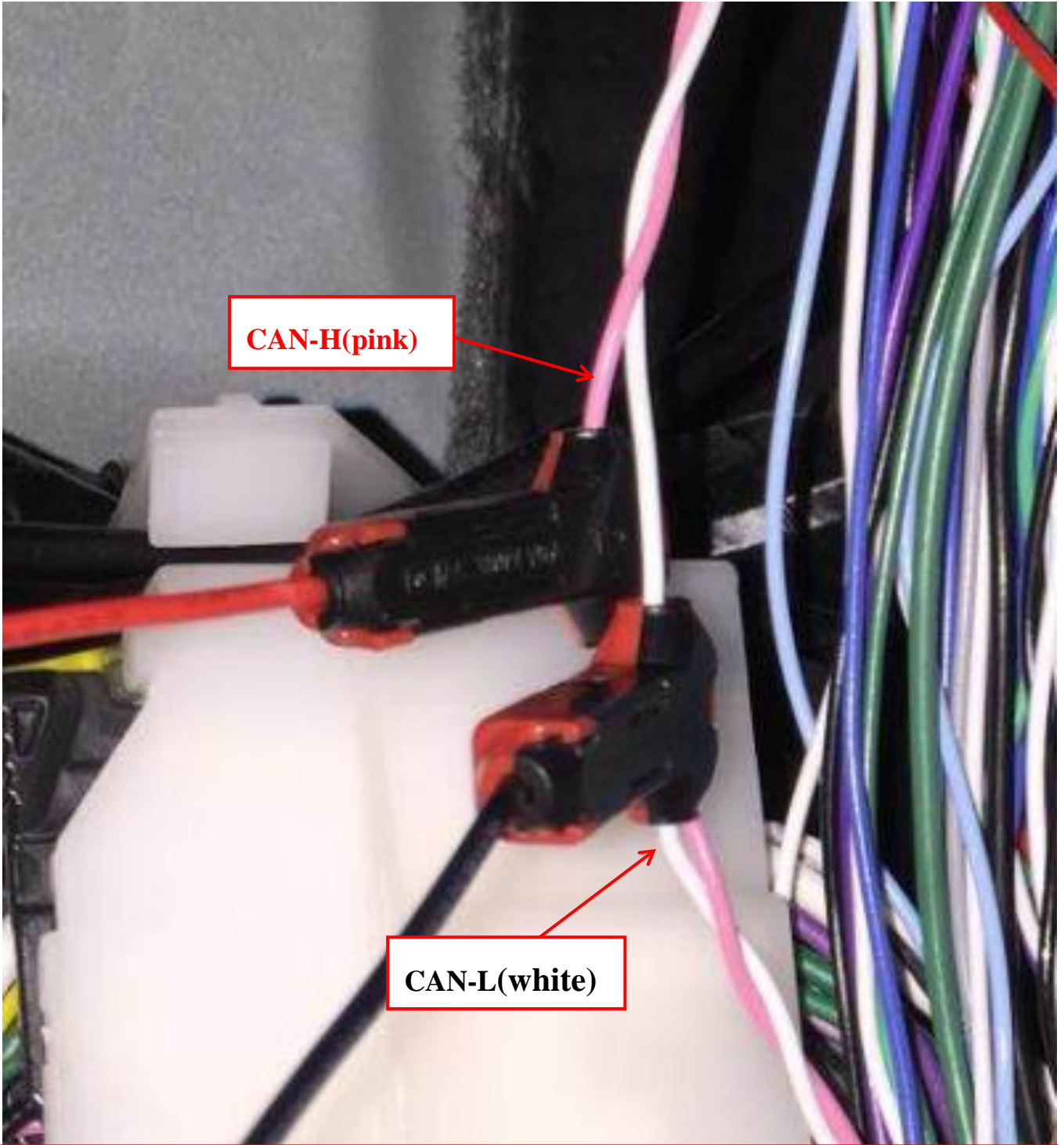

CAN-H to the red cable

CAN-L to the black cable

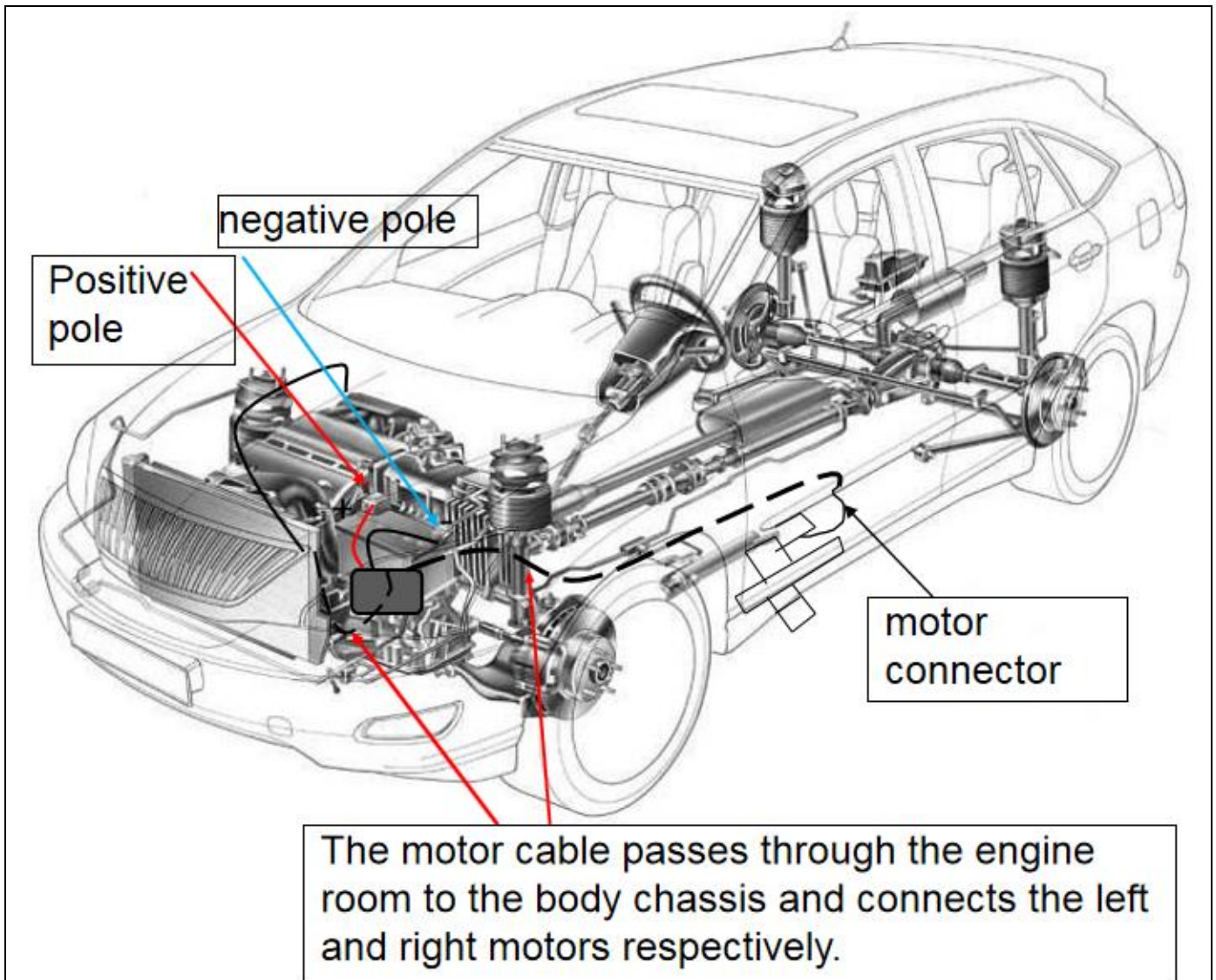

6. Installation

- 6.1 Refer to the accessories list to check whether the accessories are complete.
- 6.2 Distinguish the front, back, right and left sides of the bracket, Then place it in place with the fastener for improving the speed of installation
- 6.3 Insert the corresponding t-bolt into the plastic card respectively. In order to avoid the loading process can not be completed due to the wrong operation of t-type screws inserted into the car bottom plate.

2010+ Toyota Prado

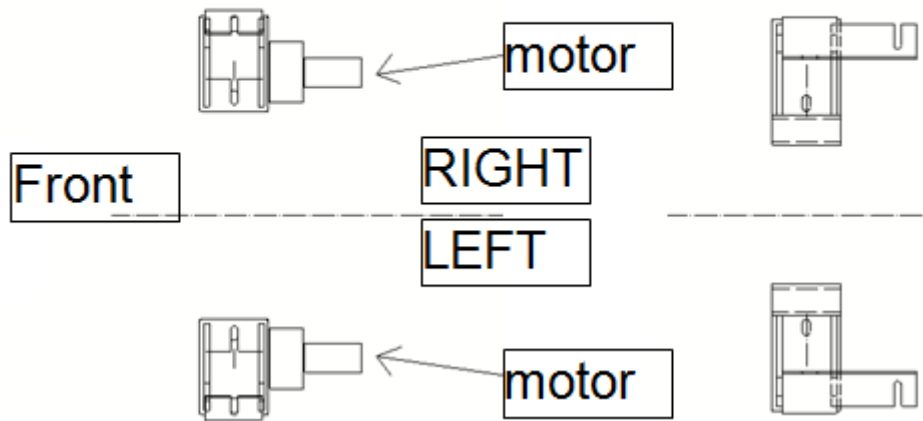

6.4 Organize the string with tie tape ,Install the removed guard plate in its original position[If there is interference between the guard plate and the bracket, the interference part should be removed].

6.5 The installation is completed, check whether there is any omission in the above installation steps.

7.Disclaimer:

Installation must be carried out in accordance with this manual. The related problems and losses caused by improper installation and use are not covered by our warranty.